



BATH CHARTER TOWNSHIP CAPITAL IMPROVEMENT PROGRAM PROJECT PROPOSAL APPLICATION

For citizen submitted proposals: It is the responsibility of the applicant to identify Township department head support or board, commission, or committee support by a majority vote for a project proposal. Failure to identify support will lead to an incomplete application. Projects will not be reviewed and/or scored without support from at least one Township department head or board, commission, or committee.

The applicant is encouraged to submit the application for the period of time that individual believes is required for the project's implementation to occur. For example, some smaller projects may need only a three-year time period for implementation to occur, while other larger projects may want to apply for the full five-year Capital Improvement Program (CIP) time period. It is important to note that projects will now, in most cases, receive two scores from the Planning Commission. The first score is an "Overall Score" of the Planning Commission's interpretation of the project and the value that will add to the community as a whole. A series of controlling metrics will be used to aid the Planning Commission in the determination of that score. The second score is a "Year One Score", this score will be associated with the Planning Commission's assessment of the research, planning, and other pre-development requirements/cost of the project. As requirements/cost can be numerous and vary from project to project, it is important for the Planning Commission to assess the pre-development efforts required of any submittal in addition to the "Overall Score".

It is also important to note, that a project submitted for a given time period will be re-assessed and re-scored on an annual basis. A CIP public hearing will be noticed to the public and the hearing will take place the night of the re-scoring. Applicants will not be required to re-submit applications on an annual basis. If the project was not implemented by the Board of Trustees at the conclusion of the previously submitted time period, the applicant can re-submit a new application.

Applicants are strongly encouraged to provide as much detail as reasonably possible. Maps, drawings, letters of support from Township committees or community organizations, etc. are all encouraged. Proposals with a distinct lack of details or information about the proposal or its purpose are likely to be rejected.

Requirements for proposal consideration:

- All information on application is complete
- Cost estimate must be from a licensed contractor or other project professional
- Project must have a minimum cost of \$20,000

- Proposed project must have a useful life of five or more years
- Must have support from at least one Township department head or board, commission, or committee by a majority vote.

For the purposes of this Capital Improvement Plan, capital improvements are generally projects related to land acquisition or infrastructure construction/improvement.

Examples of CIP Projects:

- Road construction/repaving
- Land acquisition
- Trail construction
- Sewer improvements
- Right-of-way acquisition
- Sidewalk improvement/replacement/construction
- Replacement of Township vehicles

The following are NOT CIP projects:

- Routine maintenance
- New software or hardware

NOTICE: SUBMISSION OF A COMPLETED PROJECT PROPOSAL APPLICATION DOES NOT GUARANTEE THAT IT WILL BE REVIEWED AND/OR SCORED.

Please submit the completed application to the Township Planner on or before Friday, June 30, 2023. The submission should include all project materials required for a completed application.

Applications may be submitted via the [Google Form](#) or in-person at the Township Offices, 14480 Webster Road, Bath MI 48808.

If applicants have questions, they can contact Township Planner Miles Roblyer by email at mroblyer@bathtownship.us or by phone at (517) 641-5166.

Project Name: KAYAK LAUNCH

Location: PARK LAKE

Applicant Name: BEN ZEEB

Contact Phone Number: 517 - 930 - 4961

Contact Email Address: BZEEB@BATHTOWNSHIP.US

Project Description (attach additional sheets if necessary):

INSTALL AN ADA KAYAK LAUNCH TO NORTH
OF BOAT LAUNCH AREA

Project Purpose (attach additional sheets if necessary):

PROVIDE A DESIGNATED AREA AND STRUCTURE
TO SAFELY LAUNCH KAYAKS.

Does the project contribute to the health, safety, and welfare of the community?

YES, IT WILL PROVIDE A SAFE WAY TO LAUNCH
KAYAKS FOR ALL ABILITY LEVELS

Is the project required in order to comply with local, state, or federal law?

NO

Does the project conform to adopted programs, policies, or plans?

Does the project remediate an existing or projected deficiency or hazard?

YES, THIS WILL GIVE PEOPLE A PLACE AND METHOD FOR LAUNCHING KAYAKS. CURRENTLY PEOPLE USE THE BEACH OR BOAT LAUNCH

Will the project upgrade facilities?

YES, BY GIVING ANOTHER OPTION FOR WATER ACCESS

Does the project contribute to the long-term needs of the community?

YES, BY DEVELOPING OUR PARKS ADDS TO THE OVERALL ATTRACTION FOR YEARS TO COME

What are the distributional impacts of the project?

THIS PROJECT WILL ENCOURAGE PEOPLE TO COME TO OUR PARKS, MAKING KAYAK ACCESS AVAILABLE TO EVERYONE. GIVING MORE OPPORTUNITY FOR OUTDOOR RECREATION

What is the departmental priority of the project?

Department(s) of Support: PARKS + PUBLIC WORKS, RECREATION

Board, Commission, or Committee of Support: RECREATION COMMITTEE

Consistent with adopted Township plans? Which one(s)? _____

Total Project Cost: \$38,008.00

Yearly Project Cost Breakdown

	2024	2025	2026	2027	2028
Cost					

Source of Project Cost Estimate:

LAKESIDE SERVICES + SPECIALTIES

Estimated Annual Maintenance Cost: REPAIR AS NEEDED, MINIMAL.

Source of Funding (attach additional sheets if necessary):

GENERAL FUND / ALPA / SPARK GRANT IF AWARDED

Project Funding Match Requirement (if applicable): _____

Marie Howe
Supervisor

Brenda Butler-Challender
Clerk

Jennifer Wilson
Treasurer

Karen Hildebrant
Superintendent



Joe Benzie
Trustee

Ryan Fewins-Bliss
Trustee

Cheryl Kellerman
Trustee

Al Rosekrans
Trustee

June 22, 2023

Bath Charter Township Planning Commission,

During the regular meeting of the Recreation Advisory Committee on June 12, 2023, the Committee voted to support the Capital Improvement Plan (CIP) project submissions for kayak launch at Rickard Boat Launch and bathroom shelters at Park Lake Beach. The motion was made by Trustee Joe Benzie and was seconded by Ms. Carolyn Hoard. The motion passed unanimously.

Please accept this communication as the Recreation Advisory Committee's formal support of the submitted projects.

Respectfully,

Tayler Reeves-Hodge
Township Deputy Superintendent

Lakeside Services and Specialties
4526 S M30
Beaverton, MI 48612

Estimate

Date	Estimate #
4/26/2023	2423-G

Name / Address
BEN ZEEB 14480 WEBSTER RD. BATH, MI. 48808

PH: 989-435-9619 E-MAIL: INFO@LAKESIDESVCS.COM

A 3% fee will be added to credit card transactions

Description	Qty	Cost	Total
PRELIMINARY COST ANALYSIS 4/26/2023			
80" X 10' DOCK SECTION-TAN	2	2,779.00	5,558.00
HALF HEXAGON DOCK SECTION	1	1,683.00	1,683.00
COUPLER SET WITH COMP	12	72.00	864.00
EZ PORT MAX ENTRY-TAN	2	2,213.00	4,426.00
COUPLER SET PORT TO PORT (2)	1	141.00	141.00
KIT, ADJ. ADAPTER DOCK TO EX LAUNCH VERTICAL PIN (2 PR) SS	1	713.00	713.00
KIT, EZ LAUNCH SINGLE ENTRY, LEFT (LOOKING FROM WATER TOWARD DOCK) (NO PORTS)	1	2,850.00	2,850.00
KIT, EZ LAUNCH SINGLE ENTRY, RIGHT (LOOKING FROM WATER TOWARD DOCK) (NO PORTS)	1	2,850.00	2,850.00
KIT,ACCESSIBLE TRANSFER SYSTEM W/SUPPORT GRAB RAIL AND SIGN	1	3,844.00	3,844.00
5'X16' HEAVY DUTY GANGWAY W/HANDRAIL-GRAY	1	4,078.00	4,078.00
5' GANGWAY TO FLOAT HINGE (3-POCKET) 2022 PRICE	1	711.00	711.00
5' GANGWAY TO SHORE ABUTMENT 2022 PRICE	1	426.00	426.00
STIFF-ARM BRACKET	1	348.00	348.00
STIFF ARM YOKE (DOCK SIDE)	1	156.00	156.00
SEAWALL ATTACHMENT BRACKET 2022 PRICE	3	270.00	810.00
2 3/8" OD - 10 GAUGE X 16' LONG GALVANIZED PIPE 2022 PRICE-FOR STIFF ARM ASSY	1	208.00	208.00
DEADWEIGHT BRACKET (STANDARD DUTY)-CABLE BRACKET (PAIR)	1	223.00	223.00
CABLE 3/8 STAINLESS STEEL PER FOOT	40	10.00	400.00
3/8" CABLE CLAMP	8	21.00	168.00
Turn buckle - Galvanized 2022 PRICE	2	38.00	76.00
MARKER BUOY 2022 PRICE	6	67.00	402.00
BROWN PLASTIC CURBING 2 X 4	5	114.00	570.00
CURBING BRACKETS & HW	12	14.00	168.00
SHIPPING, ASSEMBLY AND IN-WATER SET-UP		6,335.00	6,335.00
Sales Tax		0.00%	0.00
Total			\$38,008.00

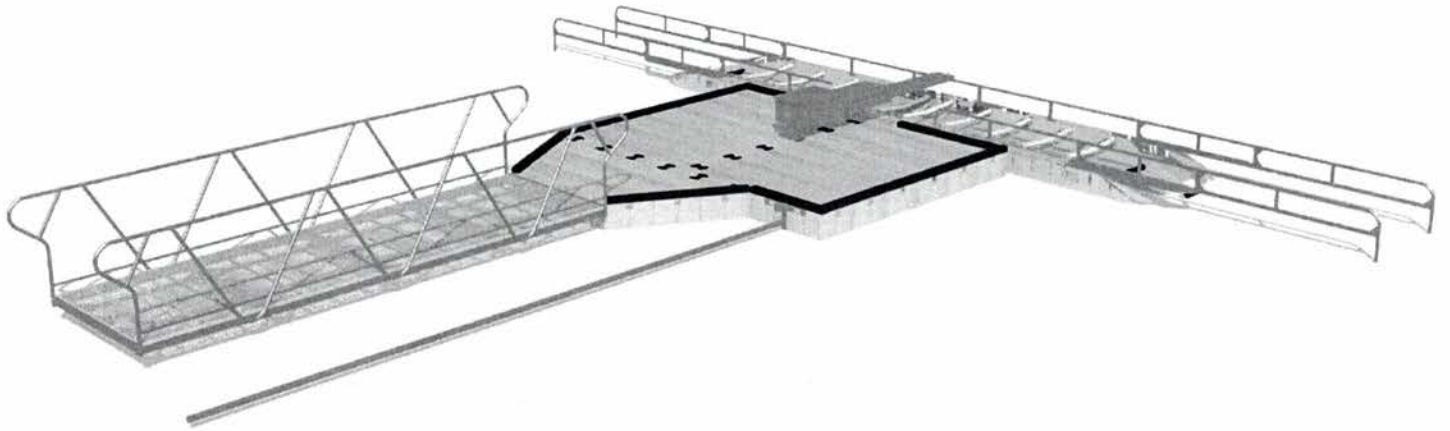

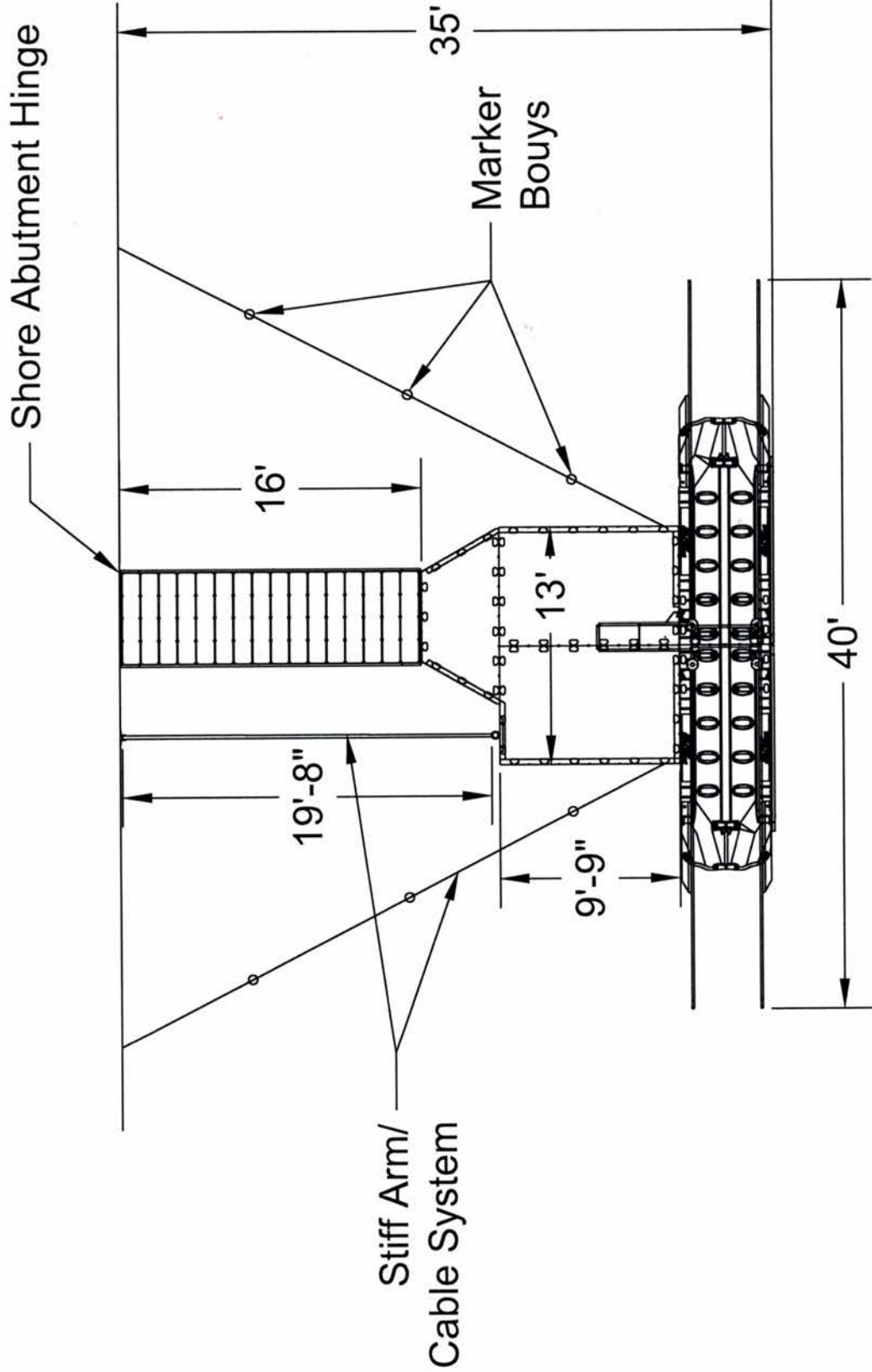

MADE IN USA

EZ Dock of Mid America



Wiswasser Park Kayak Launch

Prepared For:
Lakeside Services

Drawing Number:
EZ042323WISWASSERPARK

Drawn By: **RKU** Date: **4/23/2023**

3253 W. 1000 N
Fortville, IN 46040

PHONE NO: (317) 747-4934
EMAIL: sales@deatonstocks.com

WEBSITE: ezdocks.com